

IMPACT ACOUSTIC®

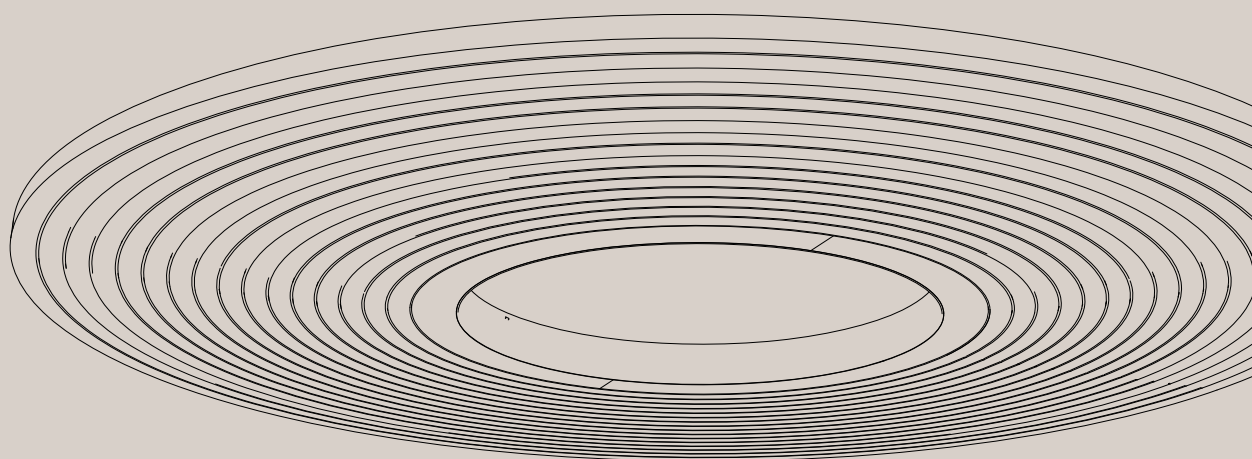

Orbis

Acoustic Lighting

722.24.41.000.00

722.24.42.000.00

TECHNICAL DATA SHEET

Orbis

Acoustic Lighting

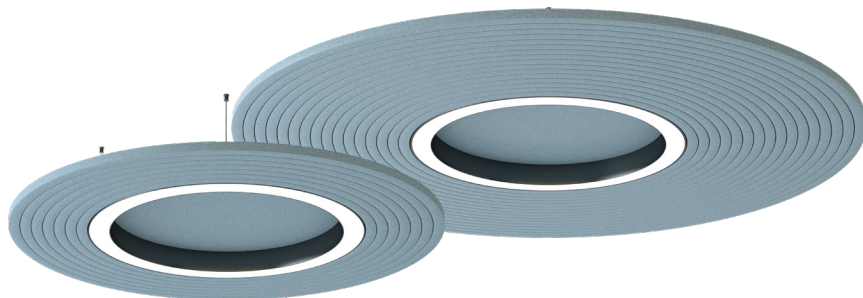

PRODUCT DIMENSIONS

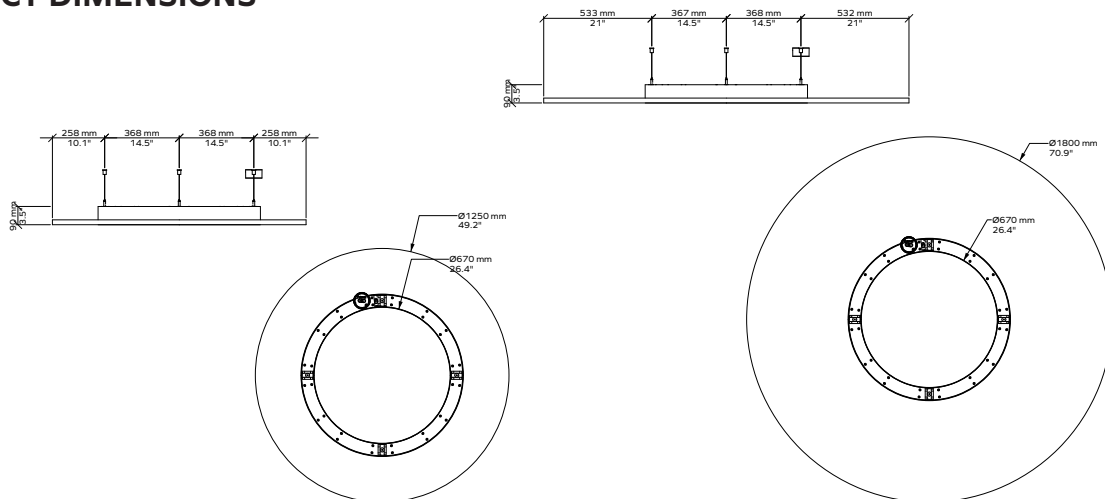

MEDIUM
722.24.41

LARGE
722.24.42

ARTICLE NUMBERS

| Lighting Product | Product Size | Color code | CCT | North American Market |
|------------------|--------------|--------------------------------|------------|---|
| 722.12. | 41 (Medium) | Choose color as shown on pg. 3 | 27 (2700K) | Add an A at the end of the CCT code to indicate this product is for North America |
| | | | 30 (3000K) | |
| | 42 (Large) | | 35 (3500K) | |
| | | | 40 (4000K) | |

Example: 722.24.41.706.35A

Orbis Medium [(1200x1200mm / 49.21x49.21", Spearmint 706 color, 3500K CCT, 110-277V (North America)]

LIGHTING SPECIFICATIONS

For both

| | | |
|-------------------------|-----------------------|-----------------|
| Output | Direct | Direct/Indirect |
| Total Lumen Output (lm) | 5630 | 8443 |
| Wattage | 50 | 75 |
| Efficacy (lm/W) | 113 | |
| Diffuser | Opal/Micropism | |
| Beam Angle | 110 | |
| CCT | 2700-3000-3500-4000K | |
| CRI | 90+ | |
| MacAdam | 3 | |
| Voltage | 220 - 240 V / 120V | |
| Dimming | 0.1% DSI/DALI Dimming | |
| Driver Location | On-Board | |

LIGHT DISTRIBUTION GRAPH

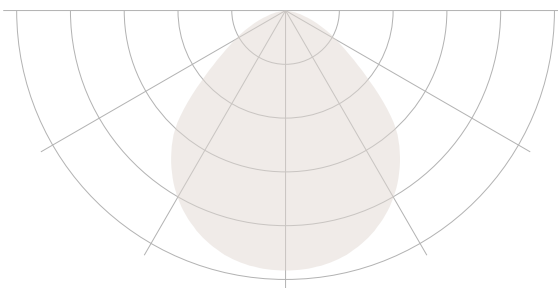

CERTIFICATIONS



ARCHISONIC®

Colors

 Material brochure available



| Name | Snow White | Milk | Cloud | Smoke | Ground | Charcoal | Slate | Raven |
|------------|------------|----------|----------|-------------|-------------|----------|----------|----------|
| Color Code | 500 | 404 | 103 | 442 | 108 | 542 | 444 | 550 |
| NCS Code | S 0300-N | S 0502-Y | S 1002-B | S 3005-R80B | S 5005-Y20R | S 7502-B | S 4500-N | S 8500-N |



| Name | Nordic Pine | Grove | Moss | Spearmint | Ice Blue | Succulent | Deep Sea | Marine Blue |
|------------|-------------|-------------|-------------|-------------|----------|-------------|-------------|-------------|
| Color Code | 311 | 317 | 439 | 706 | 304 | 712 | 918 | 864 |
| NCS Code | S 5030-G10Y | S 7020-G30Y | S 2040-G40Y | S 1010-B90G | S 0510-B | S 3020-B30G | S 5020-R90B | S 4050-R70B |



| Name | Linen | Shell Pink | Jute | Warm Stone | Terracotta | Soft Coral | Honeycomb | Sunshine |
|------------|-------------|-------------|-------------|-------------|-------------|-------------|-------------|-------------|
| Color Code | 107 | 102 | 920 | 105 | 239 | 516 | 139 | 846 |
| NCS Code | S 1505-Y30R | S 0510-R30B | S 3010-Y30R | S 3010-Y50R | S 4040-Y70R | S 2020-Y90R | S 2050-Y20R | S 1040-Y10R |



| Name | Garnet | Hot Pink | Poster Red | Electric Orange | Winter Sky | Pacific Ocean | Midnight | Grape |
|------------|-------------|-------------|------------|-----------------|-------------|---------------|-------------|-------------|
| Color Code | 724 | 140 | 662 | 464 | 311 | 432 | 810 | 540 |
| NCS Code | S 5040-R10B | S 2060-R20B | S 1080-R | S 0580-Y70R | S 5030-G10Y | S 3040-B | S 7020-R70B | S 5040-R40B |

These NCS codes are the closest visual match available and may not be exact to blended fibres.

ARCHISONIC®

Colors

Experience our ARCHISONIC® Felt material with a stunning selection of 32 colors across 8 distinct families, thoughtfully curated by *Colour Hive* in London. Effortlessly combine colors harmoniously to suit your preferences. Discover more in our Materials brochure and order your free sample box today.

Color fastness

Class 6

ISO 105-B02:A1

Order a free sample box



Orbis

Acoustic Performance

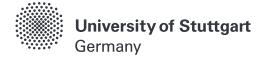

Testing Standards

| | |
|----------------|---|
| ISO 354:2003 | Acoustics — Measurement of sound absorption in a reverberation room |
| ISO 11654:1997 | Acoustics — Sound absorbers for use in buildings — Rating of sound absorption |
| ISO 20189:2018 | Acoustics — Screens, furniture and single objects intended for interior use — Rating of sound absorption and sound reduction of elements based on laboratory measurements |
| ASTM C423-17 | Standard Test Method for Sound Absorption and Sound Absorption Coefficients by the Reverberation Room Method |
| ASTM E795-16 | Standard Practices for Mounting Test Specimens During Sound Absorption Tests |

Acoustic Test Results

| | α_w | SAA | NRC |
|---|------------|------|------|
| 24mm Ceiling Panel 1800x2400mm ¹ | 0.75 (MH) | 0.85 | 0.85 |
| 12mm Ceiling Panel 1200x2800mm ¹ | 0.65 (H) | 0.74 | 0.75 |
| 24mm Ceiling Panel 1800x2400mm ² | 0.55 (MH) | 0.72 | 0.70 |

1 - Measured with 200mm airgap and open edges
 2 - Measured with 200mm airgap, open edges and 18% perforation

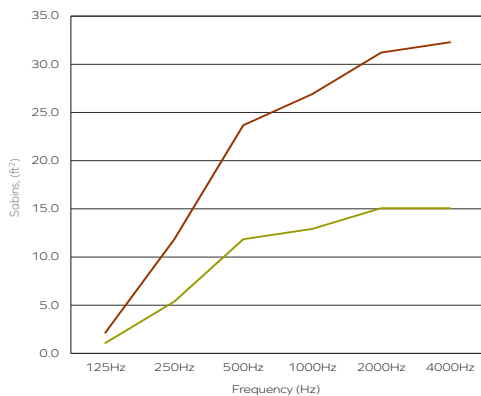

Acoustic Performance - ASTM Sabins, ft²

| Frequency (Hz) | 125 | 250 | 500 | 1000 | 2000 | 4000 |
|---------------------|------|-------|-------|-------|-------|-------|
| 24mm Orbis (Medium) | 1.08 | 5.38 | 11.84 | 12.92 | 15.07 | 15.07 |
| 24mm Orbis (Large) | 2.15 | 11.84 | 23.68 | 26.91 | 31.22 | 32.29 |

The graph represents the Sabins (ft²) in the third octave band center frequencies. Measurement used Pink Noise as excitation signal in a reverberant room.

- 24mm Orbis (Medium)
- 24mm Orbis (Large)

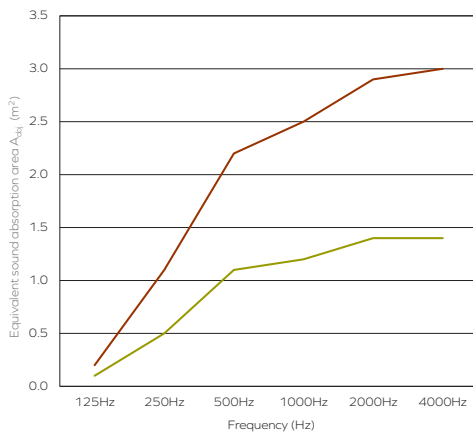

Acoustic Performance - ISO A_{obj}, m²

| Frequency (Hz) | 125 | 250 | 500 | 1000 | 2000 | 4000 |
|---------------------|------|------|------|------|------|------|
| 24mm Orbis (Medium) | 0.10 | 0.50 | 1.10 | 1.20 | 1.40 | 1.40 |
| 24mm Orbis (Large) | 0.20 | 1.10 | 2.20 | 2.50 | 2.90 | 3.00 |

The graph represents the equivalent sound absorption per object (A_{obj}) in the third octave band center frequencies. Measurement used Pink Noise as excitation signal in a reverberant room.

- 24mm Orbis (Medium)
- 24mm Orbis (Large)

ARCHISONIC® Felt

Material Specification

| | | |
|------------------------------|---|---|
| Product Name | Archisonic® Felt | |
| Content | 100% PET (60% certified post-consumer content) | |
| Thickness¹ | 12mm (0.47") | 24mm (0.94") |
| Max. Size | 1200x2800mm (47"x110") | 1800x2400mm (70"x94") |
| Acoustic² | ASTM: NRC=0.6 ISO: α_w =0.65 | ASTM: NRC=0.9 ISO: α_w =0.95 |
| Density¹ | 2400 g/m ² (0.49 lbs/ sqft) | 4000 g/m ² (0.82 lbs/sqft) |
| Color Fastness | Class 6 ISO 105-B02:A1 | |
| Color | 32 colors (see Archisonic® Felt Color page for more information) | |
| Maintenance | For daily cleaning we recommend alcohol solution (75%), e.g. Pantasept. In case of contamination by dust or fluff, use feather duster or a regular vacuum cleaner. For heavy dirt, treat the material with hydrogen peroxide. | |
| Lead time³ | 21 days | |
| Fire Rating | DIN EN 13501-1: B-s1, d0 | ASTM E84 Class A |
| VOC Emission | 28 Days French Regulation A+ ASTM E84 Pass Bream® (International, UK, NL, SE, NOR) Exemplary CDPH (CDPH/EHLB/Standard Method V1.2) Pass | |
| Certifications | Declare label, Cradle to Cradle, UL Environmental Product Declaration, Member of US Green Building Council, Ecobau 1st Priority, Climmate-KIC, VOC emissions in LEED EQ credit (low-emitting products), SCS Recycled Content | |
| Durability | Contract | |

1 - all values are nominal 2 - measured with 300mm air cavity 3 - depending on the location and type of product



Climate-KIC is supported by the EIT, a body of the European Union



Declare.



Orbis

Acoustic Lighting

Online Resources

A variety of resources are available online for all of our products. Please visit the product's page for more information.



CAD files
IES/LDT files



Spec sheets and
Installation Guide



Color families



Instruction
videos



Associated
products specs.

Ordering Process

Our experienced team of Project Consultants will guide and support you throughout the order process. We fulfill the majority of our orders in as little as 21 days¹ from your first point of contact, allowing you to focus on what truly matters to you.



Contact our
consultant

Quote¹

48 h



Order Confirmation

Production¹

2 - 3 weeks



Dispatch

Transit

location based



Delivery

Contact Us

Ready to make an impact? We are just an email or call away to discuss your project and answer any question.



+41 41 566 55 55



connect@impactacoustic.com



Online form

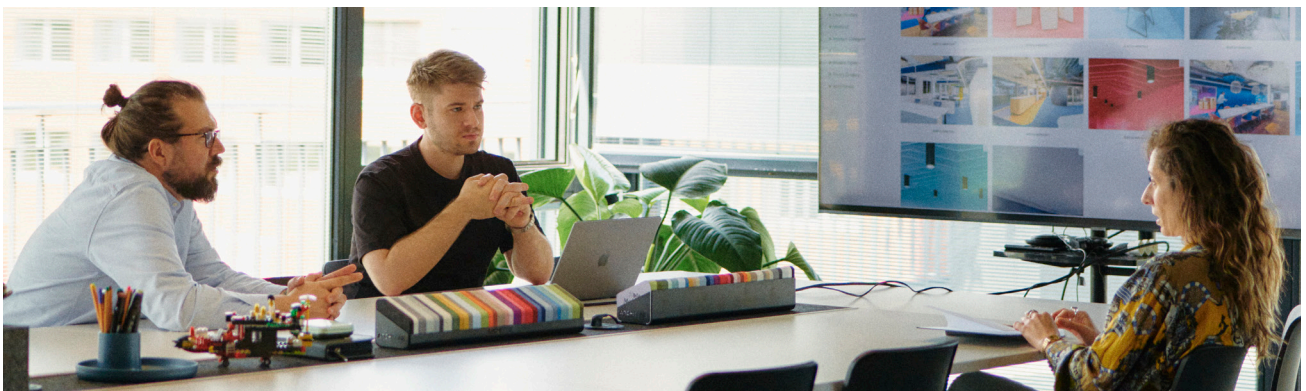

¹ - Quote and Production times may vary.

**#We
Make An
Impact**

connect@impactacoustic.com | www.impactacoustic.com